



Fall Protection

Conforms to the requirements of 29 CFR OSHA 1910.140 and 29 CFR OSHA 1926.502

**3M™ PROTECTA®
SELF-RETRACTING DEVICES**

**USER INSTRUCTIONS
5908128 REV. A**

☑ For identification of product codes, refer to Table 1. See "Table 1 - Product Specifications" for more product information.

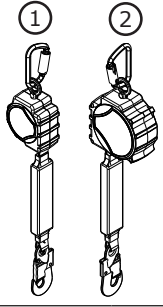
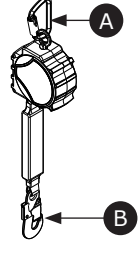
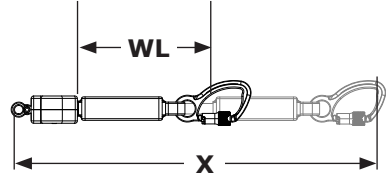
OSHA								
	Model		Connectors		Housing Size	Lifeline	Extended Length (X)	Working Length (WL)
			A	B				
✓	3100513	①	C1	C2	Size A	DP1	11 ft. (3.4 m)	9.4 ft. (2.9 m)
✓	3100514	①	C1	C3	Size A	DP1	11 ft. (3.4 m)	9.4 ft. (2.9 m)
✓	3100515	①	C1	C4	Size A	DP1	11 ft. (3.4 m)	9.4 ft. (2.9 m)
✓	3100516	①	C2	C3	Size B	DP1	20 ft. (6.1 m)	18.5 ft. (5.6 m)

EN SAFETY INFORMATION

Please read, understand, and follow all safety information contained in these instructions, prior to the use of this product. FAILURE TO DO SO COULD RESULT IN SERIOUS INJURY OR DEATH.

These instructions must be provided to the user of the equipment. Retain these instructions for future reference.

Intended Use:

This product is used as part of a complete Fall Protection system.

Use in any other application including, but not limited to, material handling, recreational or sports-related activities, or other activities not described in these instructions, is not approved by 3M and could result in serious injury or death.

This product is only to be used by trained users in workplace applications.

WARNING

This product is used as part of a complete Fall Protection system. All users must be fully trained in the safe installation and operation of their complete Fall Protection system. **Misuse of this product could result in serious injury or death.** For proper selection, operation, installation, maintenance, and service, refer to all instruction manuals and manufacturer recommendations. For more information, see your supervisor or contact 3M Technical Services.

- **To reduce the risks associated with using a Self-Retracting Device which, if not avoided, could result in serious injury or death:**
 - Inspect the product before each use and after any fall event, in accordance with the procedures specified in these instructions.
 - If inspection reveals an unsafe or defective condition, remove the product from service immediately and clearly tag it "DO NOT USE". Destroy or repair the product as required by these instructions.
 - Any product that has been subject to fall arrest or impact force must be immediately removed from service. Destroy or repair the product as required by these instructions.
 - Ensure that Fall Protection systems assembled from components made by different manufacturers are compatible and meet all applicable Fall Protection regulations, standards, or requirements. Always consult a Competent or Qualified Person before using these systems.
 - Ensure the product is kept free from all hazards including, but not limited to: entanglement with users, other workers, moving machinery, other surrounding objects, or impact from overhead objects that could fall onto the product or users.
 - Do not twist, tie, knot, or allow slack in the lifeline.
 - Avoid trip hazards with legs of the lifeline. Attach any unused lifeline legs to the lanyard parking elements on your full body harness, if present.
 - Do not exceed the number of allowable users specified in these instructions.
 - Do not use in applications that have an obstructed fall path. A clear path is required to lock the SRD. Working on slowly shifting materials (e.g. sand or grain), or within confined spaces or limited spaces, may not allow the worker to reach sufficient speed to lock the SRD.
 - Avoid sudden or quick movements during work operation because this may cause the SRD to unintentionally lock.
 - Use caution when installing, using, or moving the product as moving parts may create pinch points.
 - Use appropriate edge protection when the product may contact sharp edges or abrasive surfaces.
 - Ensure the product is configured and installed properly for safe operation as described in these instructions.
 - Immediately remove the product from service if it has been used in a descent.
 - Before use, ensure the descent path and landing area are clear of any obstructions or hazards.

- **To reduce the risks associated with working at height which, if not avoided, could result in serious injury or death:**
 - Your health and physical condition must allow you to safely work at height and to withstand all forces associated with a fall arrest event. Consult your doctor if you have questions regarding your ability to use this equipment.
 - Never exceed allowable capacity of your Fall Protection equipment.
 - Never exceed the maximum free fall distance specified for your Fall Protection equipment.
 - Do not use any Fall Protection equipment that fails inspection, or if you have concerns about the use or suitability of the equipment. Contact 3M Technical Services with any questions.
 - Some subsystem and component combinations may interfere with the operation of this equipment. Only use compatible connections. Contact 3M Technical Services before using this equipment in combination with components or subsystems other than those described in these instructions.
 - Use extra precautions when working around moving machinery, electrical hazards, extreme temperatures, chemical hazards, explosive or toxic gases, sharp edges, abrasive surfaces, or below overhead materials that could fall onto you or your Fall Protection equipment.
 - Ensure use of your product is rated for the hazards present in your work environment.
 - Ensure there is sufficient fall clearance when working at height.
 - Never modify or alter your Fall Protection equipment. Only 3M, or persons authorized in writing by 3M, may make repairs to 3M equipment.
 - Before using Fall Protection equipment, ensure a written rescue plan is in place to provide prompt rescue if a fall incident occurs.
 - If a fall incident occurs, immediately seek medical attention for the fallen worker.
 - Only use a full body harness for Fall Arrest applications. Do not use a body belt.
 - Minimize swing falls by working as directly below the anchorage point as possible.
 - A secondary Fall Protection system must be used when training with this product. Trainees must not be exposed to an unintended fall hazard.
 - Always wear appropriate Personal Protective Equipment when installing, using, or inspecting the product.
 - Never work below a suspended load or worker.
 - Always maintain 100% tie-off.

☑ Always ensure you are using the latest revision of your 3M instruction manual. Visit www.3m.com/userinstructions or contact 3M Technical Services for updated instruction manuals.

PRODUCT OVERVIEW:

Figure 1 illustrates the 3M™ Protecta® Self-Retracting Device (SRD). Protecta SRDs are drum-wound wire rope or synthetic rope lifelines that retract into thermoplastic or aluminum housings. Protecta SRDs are designed for overhead applications where the SRD is mounted above the user and the lifeline remains vertical during use.

The following SRD types are covered by this instruction:

- **Self-Retracting Device (Figures 1.1, 1.2; 2.1, 2.2):** Self-Retracting Devices (SRDs) are suitable for applications where the lifeline remains generally vertical during use. This type may be used for Fall Arrest or Restraint applications.

Figure 2 identifies key components of the available SRD models. In a standard SRD, the Lifeline (A) extends and retracts from within the Housing (B). The Top Connector (D) secures the SRD to its mounting point and is connected to the SRD by means of the Swivel Eye (E). The Bottom Connector (C) is secured at the end of the Lifeline. Depending on system configuration, the Bottom Connector will attach to either the designated attachment element of the user's full body harness or to the system's anchorage point. Energy Absorbers (F) dissipate kinetic energy and limit deceleration forces during fall arrest.

Each product model has its own particular size and its own combination of components as listed in Figure 1. See Table 1 for more information on Component Specifications.

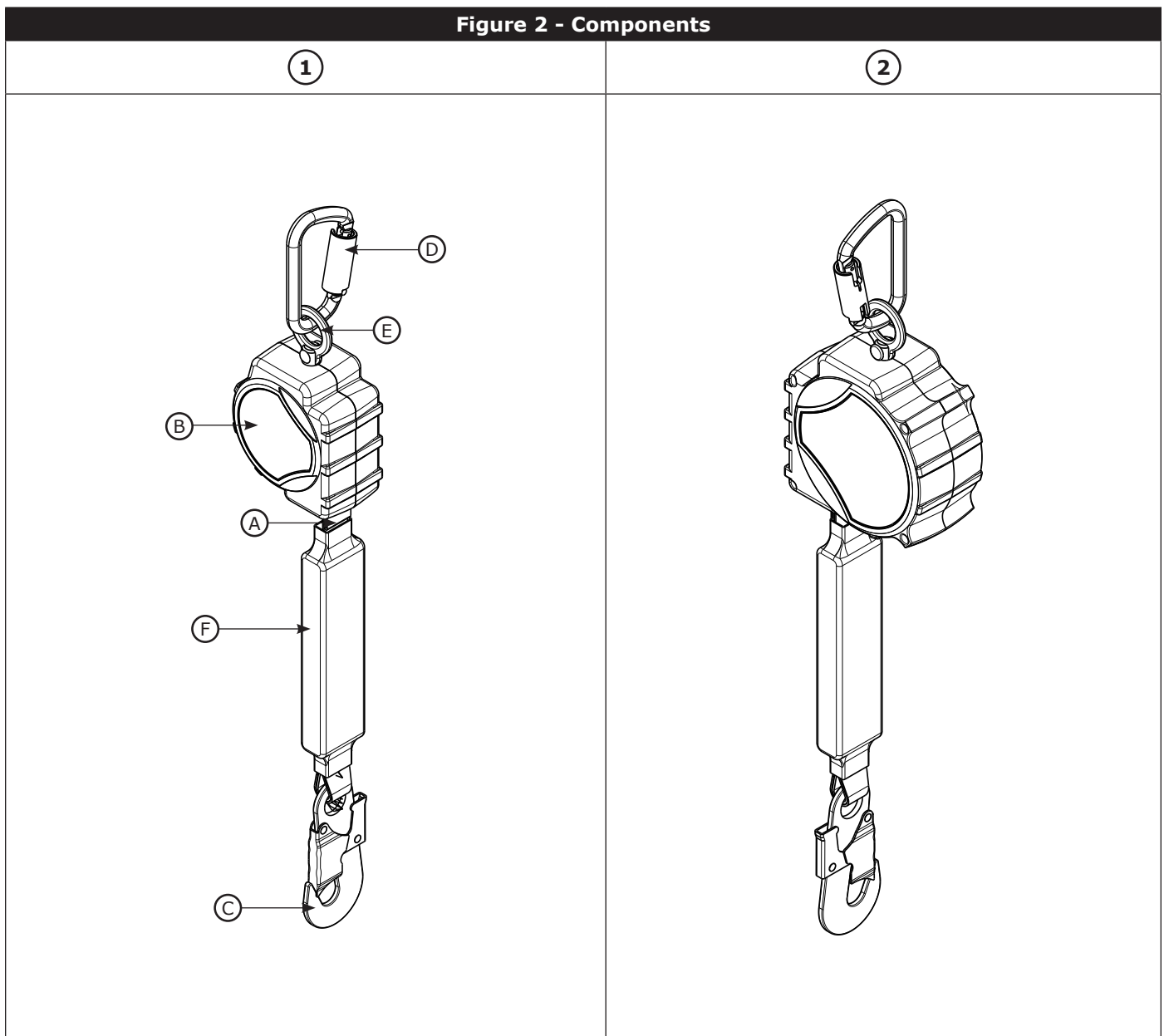

Before using this equipment, record the product identification information from the ID label in the 'Inspection and Maintenance Log' at the back of this manual.

Table 1 – Product Specifications

System Specifications:

Anchorage:	The anchorage structure for the SRD must be capable of supporting loads up to 3,372 lbf (15kN).
Service Temperature:	-40°F to 130°F (-40°C to 54.4°C)
Standards:	Each product model is certified to, or conforms with, the applicable standards and regulations listed within Figure 1.

Component Specifications:

Figure 2 Reference	Component	Materials
(A)	Lifeline	(see Lifeline Specifications)
(B)	Housing	Nylon
(C)	Bottom Connector	(see Connector Specifications)
(D)	Top Connector	(see Connector Specifications)
(E)	Swivel Eye	Steel
(F)	Energy Absorber	Vinyl cover with polyester lifeline
---	Drum	Nylon

Internal Components: Internal SRD components are made from a combination of Stainless Steel, Steel, and Aluminum.

Connector Specifications:

Figure 1 Reference	Model Number	Description	Material	Gate Opening	Gate Strength
C1	2000193	Carabiner	Steel	11/16-in. (19 mm)	3,600 lbf (16 kN)
C2	2000161	Self-Locking Snap Hook	Steel	3/4-in. (19 mm)	3,600 lbf (16 kN)
C3	2000178	Swivel Self-Locking Snap Hook	Steel	3/4-in. (19 mm)	3,600 lbf (16 kN)
C4	2000118	Rebar Hook	Steel	2 1/4 in (57mm)	3,600 lbf (16 kN)

Tensile Strength: The tensile strength of each of the connectors listed above is 22.2 kN (5,000 lbf).

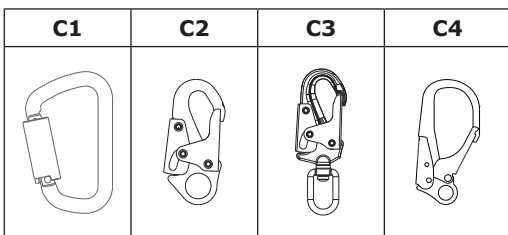

Lifeline Specifications:

Figure 1 Reference	Description
DP1	1 in. Polyester Diamond Weave (0.056 in. Thick)

Table 1 – Product Specifications

Performance - SRDs	OSHA Models
Capacity Range:	130 - 310 lbs. (59-141 kg)
Maximum Arresting Force:	1,800 lbf (8 kN)
Average Arresting Force:	N/A
Maximum Arrest Distance: <i>*Assumes the SRD is mounted directly above the user.</i>	48 in. (1.2m)
Maximum Deceleration Distance: <i>*Assumes the SRD is mounted directly above the user.</i>	42 in. (1.1 m)
Minimum Fall Clearance Required: <i>*Assumes the SRD is mounted directly above the user.</i>	6 ft (1.8 m)
Maximum Free Fall: <i>*SRD must be mounted above user's D-ring.</i>	2 ft (0.6 m)

Dimensions:				
Figure 1 Reference	D	W	R	
Size A	2.6 in. (6.6 cm)	4.2 in. (10.7 cm)	25 in. (63.5 cm)	
Size B	2.8 in. (7.1 cm)	5.7 in. (14.5 cm)	22.5 in. (57.1 cm)	

1.0 PRODUCT APPLICATION

- 1.1 PURPOSE:** 3M Self-Retracting Devices (SRDs) are designed for use as a connecting subsystem in a Fall Protection system. Once anchored, the lifeline extends and retracts automatically as the worker moves. If a fall occurs, a sensing mechanism activates the device and arrests the fall. For more information on system applications, refer to the "Product Overview" and Table 1.
- 1.2 SUPERVISION:** Use of this equipment must be supervised by a Competent Person.
- 1.3 STANDARDS:** Your product conforms to the national or regional standards identified on the front cover of these instructions. If this product is resold outside the original country of destination, the re-seller must provide these instructions in the language of the country in which the product will be used.

For more information on certification or conformance requirements, refer to the applicable standards and regulations listed for your product (e.g. the ANSI/ASSP Z359 Fall Protection codes).

- 1.4 TRAINING:** This equipment must be installed and used by persons trained in its correct application. These instructions are to be used as part of an employee training program as required by national, regional, or local standards. It is the responsibility of the users and installers of this equipment to ensure they are familiar with these instructions, trained in the correct care and use of this equipment, and are aware of the operating characteristics, application limitations, and consequences of improper use of this equipment.
- 1.5 RESCUE PLAN:** When using this equipment and connecting subsystems, the employer must have a written rescue plan and the means to implement and communicate that plan to users, authorized persons, and rescuers. A trained, on-site rescue team is recommended. Team members should be provided with the equipment and techniques necessary to perform a successful rescue. Training should be provided on a periodic basis to ensure rescuer proficiency. Rescuers should be provided with these instructions. There should be visual contact or means of communication with the person being rescued at all times during the rescue process.

2.0 SYSTEM REQUIREMENTS

- 2.1 ANCHORAGE:** Anchorage requirements vary with the Fall Protection application. The mounting structure on which the equipment is placed must meet the Anchorage specifications defined in Table 1.
- 2.2 CAPACITY:** The user capacity of a complete Fall Protection system is limited by its lowest rated maximum capacity component. For example, if your connecting subsystem has a capacity that is less than your harness, you must comply with the capacity requirements of your connecting subsystem. See the manufacturer instructions for each component of your system for capacity requirements.
- 2.3 ENVIRONMENTAL HAZARDS:** Use of this equipment in areas with environmental hazards may require additional precautions to prevent injury to the user or damage to the equipment. Hazards may include, but are not limited to: high heat, chemicals, corrosive environments, high voltage power lines, explosive or toxic gases, moving machinery, sharp edges, or overhead materials that may fall and contact the user or equipment. Contact 3M Technical Services for further clarification.
- 2.4 LIFELINE HAZARDS:** Ensure the lifeline is kept free from all hazards including, but not limited to: entanglement with users, other workers, moving machinery, other surrounding objects, or impact from overhead objects that could fall onto the lifeline or users.
- 2.5 FALL PATH AND SRD LOCKING SPEED:** Do not use in applications that have an obstructed fall path. A clear path is required to lock the SRD. Working on slowly shifting materials (e.g. sand or grain), or within limited spaces, may not allow the worker to reach sufficient speed to lock the SRD.
- 2.6 COMPONENT COMPATIBILITY:** 3M equipment is designed for use with 3M equipment. Use with non-3M equipment must be approved by a Competent Person. Substitutions made with non-approved equipment may jeopardize equipment compatibility and may affect the safety and reliability of your Fall Protection system. Read and follow all instructions and warnings for all equipment prior to use.
- 2.7 CONNECTOR COMPATIBILITY:** Connectors are compatible with connecting elements when the size and shape of either component does not cause the connector to inadvertently open, regardless of orientation. Connectors must comply with applicable standards. Connectors must be fully closed and locked during use.

3M Connectors (snap hooks and carabiners) are designed to be used only as specified in each instruction manual. Ensure connectors are compatible with the system components to which they are connected. Do not use equipment that is non-compatible. Use of non-compatible components may cause the connector to unintentionally disengage (see Figure 3). If the connecting element to which a connector attaches is undersized or irregular in shape, a situation could occur where the connecting element applies a force to the gate of the connector (A). This force could then cause the gate to open (B), disengaging the connector from the connecting element (C).

2.8 MAKING CONNECTIONS: All connections must be compatible in size, shape, and strength. See Figure 4 for examples of inappropriate connections. Do not attach snap hooks and carabiners:

- A. To a D-Ring to which another connector is attached.
- B. In a manner that would result in a load on the gate. Large-throat snap hooks should not be connected to standard-size D-Rings or other connecting elements, unless the snap hook has a gate strength of 16 kN (3,600 lbf) or greater.
- C. In a false engagement, where size or shape of the connector or connecting element is not compatible and, without visual confirmation, would seem to be fully engaged.
- D. To each other.
- E. Directly to webbing or rope lanyard or tie-back material, unless the instruction manuals for both the lanyard and connector specifically allow such a connection.
- F. To any object whose size or shape does not allow the connector to fully close and lock, or that could cause connector roll-out.
- G. In a manner that does not allow the connector to align properly while under load.

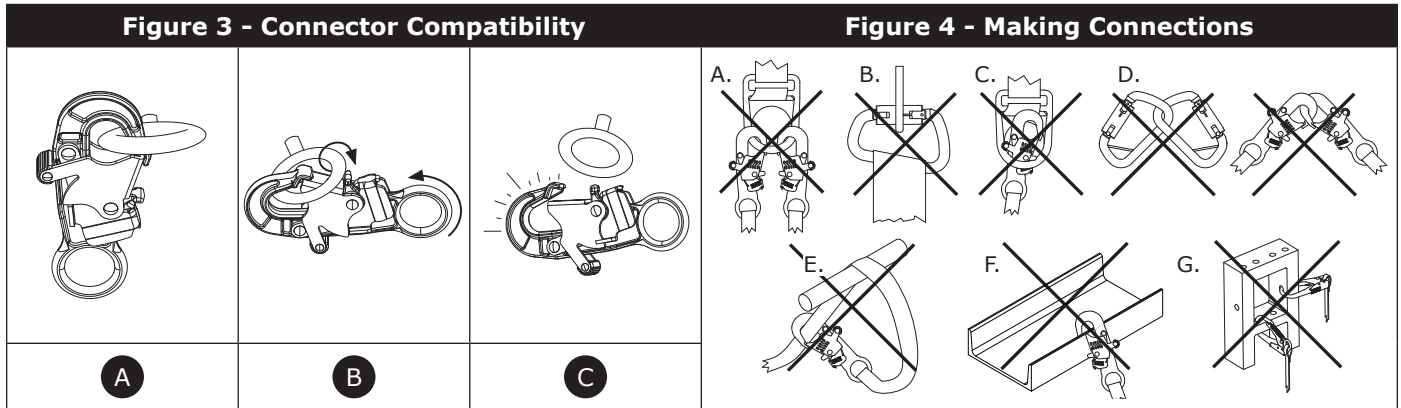

3.0 INSTALLATION

3.1 OVERVIEW: Installing this product requires effective planning and knowledge of fall clearance requirements. In the event of a fall, there must be enough fall clearance present to safely arrest the user.

3.2 PLANNING: Plan your Fall Protection system before starting your work. Account for all factors that may affect your safety before, during, and after a fall. Consider all requirements and limitations specified in these instructions.

A. SHARP EDGES: Avoid working where system components may be in contact with, or scrape against, unprotected sharp edges and abrasive surfaces. All sharp edges and abrasive surfaces should be covered with protective material.

Only SRD-LEs may be used for applications with unprotected sharp edges or abrasive surfaces.

3.3 FALL CLEARANCE: It is critical that the user is aware of fall clearance and its requirements before using this product.

A. DEFINITION: Fall clearance is the measure of distance between a user and the next obstruction below them. Before use of this product, the user should determine how much fall clearance is required to prevent them from striking an obstruction should they fall.

A user's **Required Fall Clearance (FC)** is the sum of **Free Fall (FF)**, **Deceleration Distance (DD)**, **Harness Stretch (HS)**, and a **Safety Factor (SF)**. See Figure 5.1 for reference.

- **Free Fall (FF)** is the distance the user travels before activation of the deceleration device.
- **Deceleration Distance (DD)** is the distance the user falls measured from activation of the deceleration device until stopping.
- **Harness Stretch (HS)** is the amount of slack extending from the user's harness when the user is suspended by their harness attachment element.
- **Safety Factor (SF)** is a set amount of distance added to fall clearance to ensure user safety.

There may be additional factors affecting Required Fall Clearance within your Fall Arrest system, such as D-ring extension length and anchorage deflection. For coverage of these factors, and others not outlined above, refer to the manufacturer instructions for each component of your Fall Arrest system. Additional factors, when provided, should be added to the fall clearance values in this instruction.

B. MINIMIZING REQUIREMENTS: The user should always position their Fall Arrest system to minimize fall potential and potential fall distance. To keep fall clearance requirements to a minimum, it is recommended that the user work as directly below their anchorage point as possible.

- **ANCHORAGE HEIGHT:** The Required Fall Clearance (FC) for a user increases as Anchorage Height (A) decreases. The user experiences a greater amount of free fall when connected to an anchorage point below them, since the user will have to travel that much farther should they fall. See Figure 5.2 for reference.
- **SWING FALLS:** The Required Fall Clearance (FC) for a user increases as User Work Radius (W) increases. Swing falls occur when the anchorage point is not directly above the user when a fall occurs. See Figure 5.3 for reference. The force of striking an object during a swing fall could cause serious injury or death. Do not permit a swing fall if injury could occur.

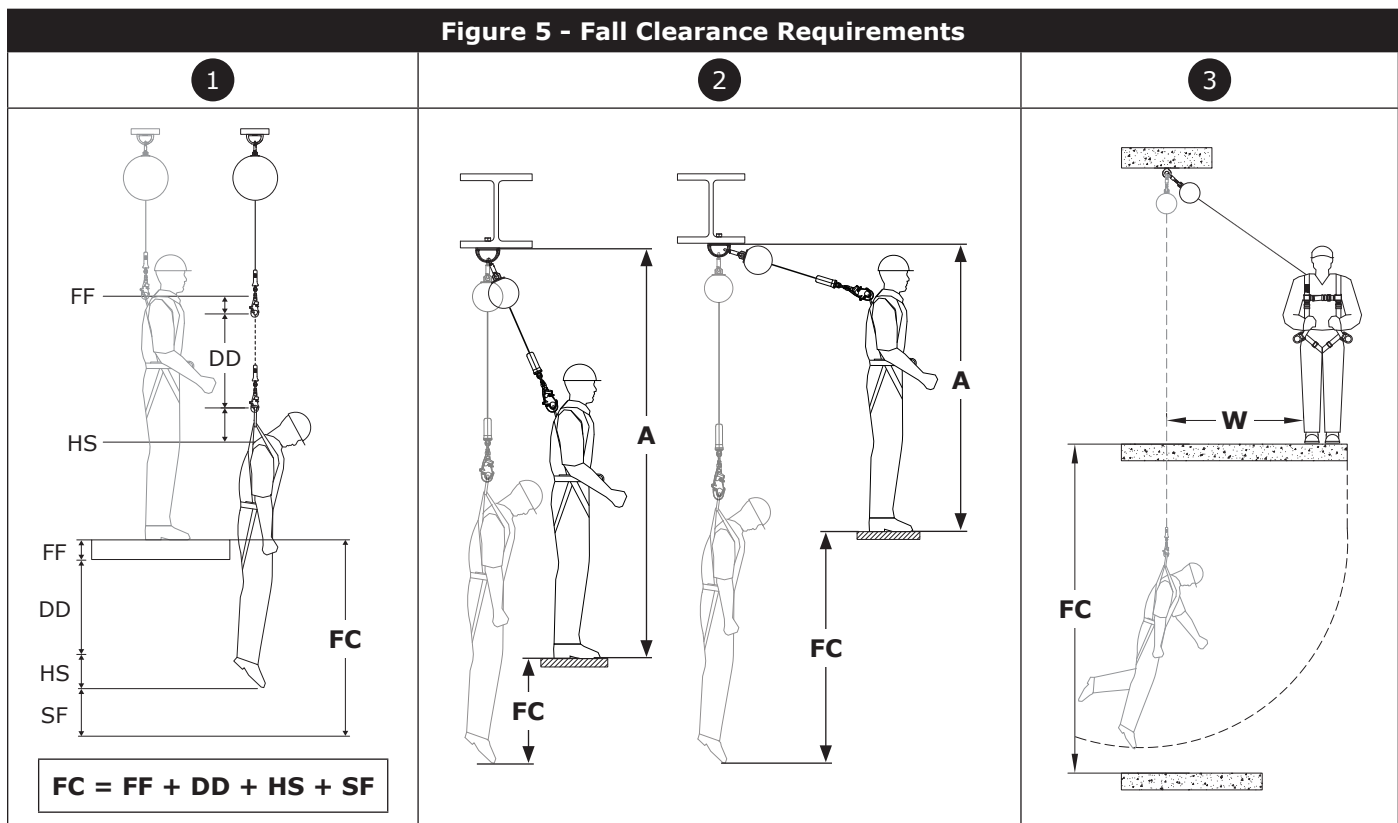

FALL CLEARANCE CHARTS

Required Fall Clearance has been provided within the charts below. To determine Required Fall Clearance:

1. Select the clearance chart that matches your product type and includes a capacity fitting your combined weight.
2. Determine the Anchorage Height (A) of your subsystem. Anchorage Height is measured from the top of the working platform to the bottom of your anchorage connection point.
3. Determine the Setback Distance (B) of your system. Setback Distance is measured from directly below your anchorage connection point to the edge of the working platform.
4. After obtaining your Anchorage Height (A) and Setback Distance (B), use (A) and (B) within the Fall Clearance Chart to determine your Required Fall Clearance (FC).

When values for (A) and (B) measured by the user do not match those listed in the table, the user should round up to the next highest listed value. If there is no higher listed value, then the user should reduce their intended Anchorage Height or Setback Distance to a lower value.

A Safety Factor of 0.45 m (1.5 ft.) and a user height of 1.8 m (6.0 ft.) were used for all values listed. Kneeling or crouching will reduce effective user height and will require an additional 1.0 m (3.28 ft.) of Fall Clearance.

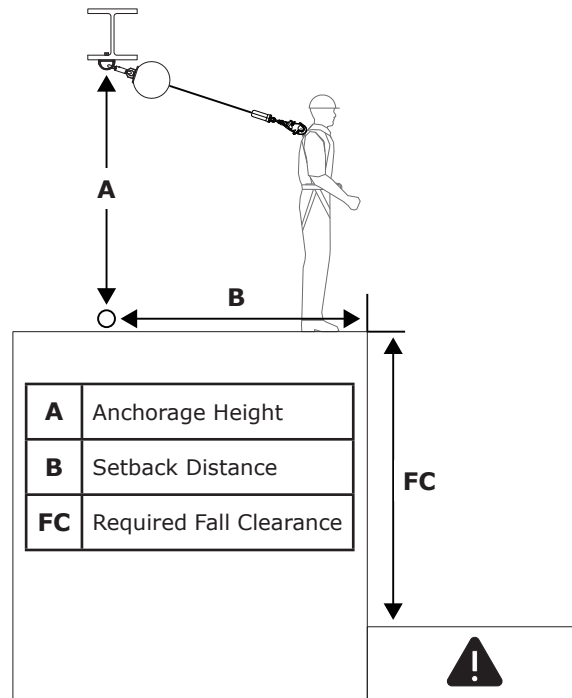

SRD: 130 lb. - 420 lb. (59 kg - 191 kg)		B				
		0 ft. (0.0 m)	3 ft. (0.9 m)	6 ft. (1.8 m)	9 ft. (2.7 m)	12 ft. (3.7 m)
A	<8 ft. (2.4 m)	4.0 ft. (1.2 m)	6.3 ft. (1.9 m)			
	8 ft. (2.4 m)	4.0 ft. (1.2 m)	5.3 ft. (1.6 m)			
	10 ft. (3.0 m)	4.0 ft. (1.2 m)	4.9 ft. (1.5 m)	7.0 ft. (2.1 m)		
	15 ft. (4.6 m)	4.0 ft. (1.2 m)	4.5 ft. (1.4 m)	5.7 ft. (1.7 m)	7.6 ft. (2.3 m)	
	20 ft. (6.1 m)	4.0 ft. (1.2 m)	4.3 ft. (1.3 m)	5.2 ft. (1.6 m)	6.5 ft. (2.0 m)	8.3 ft. (2.5 m)
	25 ft. (7.6 m)	4.0 ft. (1.2 m)	4.2 ft. (1.3 m)	4.9 ft. (1.5 m)	6.0 ft. (1.8 m)	7.4 ft. (2.2 m)
	30 ft. (9.1 m)	4.0 ft. (1.2 m)	4.2 ft. (1.3 m)	4.7 ft. (1.4 m)	5.6 ft. (1.7 m)	6.8 ft. (2.1 m)
	FC					

3.5 CONNECTING TO ANCHORAGE: Figure 6 illustrates typical SRD anchorage connections. The Anchorage (A) should be directly overhead to minimize free fall and swing fall hazards (see Section 3.3.B). Select an anchorage capable of sustaining the static loads defined in Table 1. Depending on system and product configuration, the user may secure the Top Connector (B) of the SRD directly to the anchorage structure or to an anchorage connector or anchorage connection point between.

3.6 CONNECTING TO A HARNESS: Connection of the SRD to a harness will vary per the harness and which attachment element is used. See Figure 7 for reference. To secure, connect the Bottom Connector (A) of the SRD to the Attachment Element (B) of the full body harness. For more information as to which attachment elements may be used, see the manufacturer instructions of your harness.

The "Product Overview" specifies for which Fall Protection applications your SRD model may be used. Ensure use of your harness complies with these requirements. A full body harness is required for Fall Arrest applications.

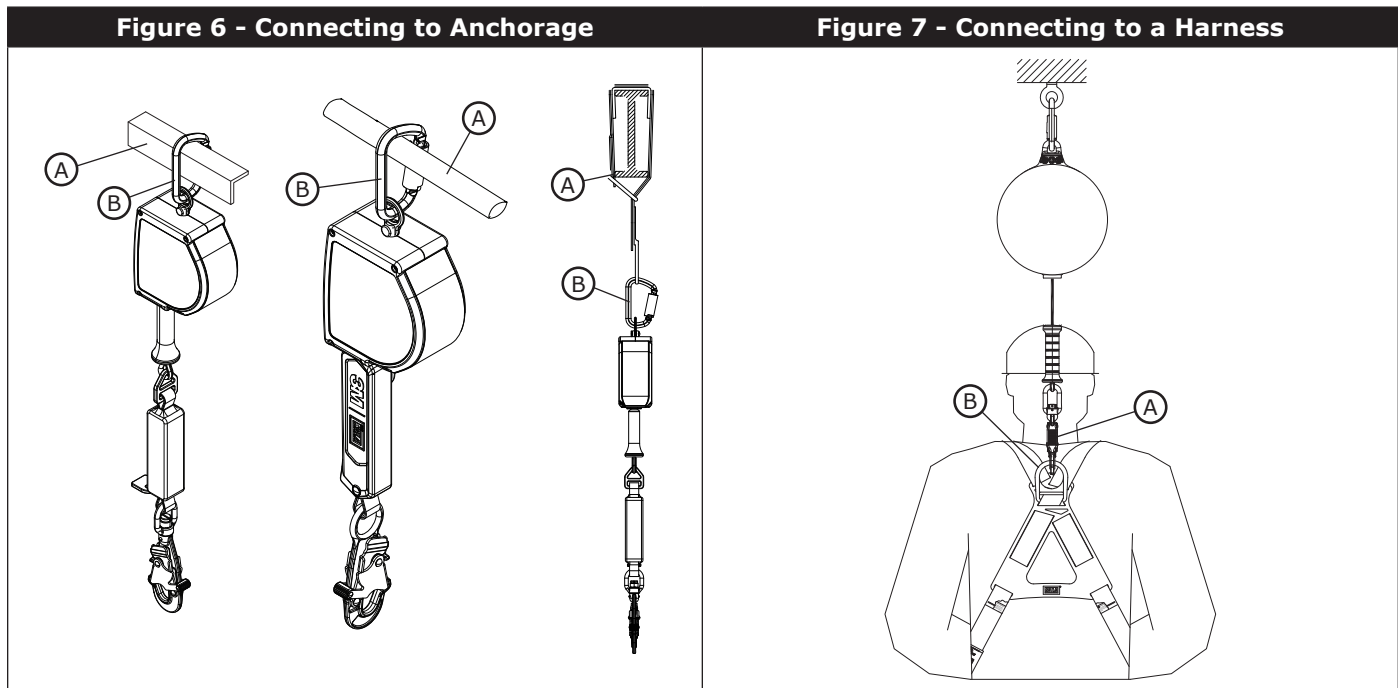

4.0 USE

4.1 BEFORE EACH USE: Verify that your work area and Fall Protection system meet all criteria defined in these instructions. Verify that a formal Rescue Plan is in place. Inspect the product per the 'User' inspection points defined in the "Inspection and Maintenance Log". If inspection reveals an unsafe or defective condition, or if there is any doubt about its condition for safe use, remove the product from service immediately. Clearly tag the product "DO NOT USE". See Section 5 for more information.

4.2 AFTER A FALL: If this equipment is subjected to fall arrest or impact force, remove it from service immediately. Clearly tag it "DO NOT USE". See Section 5 for more information.

4.3 OPERATION: Before using an SRD, the worker will need to secure the SRD to an anchorage connection point and an attachment element on their full body harness. Once secured, the worker may move within the established safe working area at normal speeds. During use, always allow the SRD lifeline to recoil back into the device under control.

4.4 TAGLINES: Depending on the worksite and system configuration, the user may not always be able to reach the SRD at its anchor point. In these situations, a tagline may be necessary. A tagline is a long piece of cord that loops through the bottom connector of the SRD before looping back in on itself. When connected in this way, the user can raise or lower the bottom connector of the SRD to their location by pulling on the tagline.

Ensure the free end of the tagline does not become entangled with other workers, equipment, or machinery. If necessary, restrain the free end of the tagline.

4.5 USE WITH HORIZONTAL SYSTEMS: The SRDs covered in this instruction are compatible for use with horizontal systems, such as Horizontal Lifeline (HLL) systems and horizontal rail systems. See the manufacturer instructions of your horizontal system for more information on its compatibility with SRDs. SRDs may be used with a horizontal system only if both products allow for such use.

Required Fall Clearance values presented in these instructions are based on use with a rigid, stationary anchorage point. These values do not apply when the product is used with a Horizontal Lifeline (HLL) system. See the manufacturer instructions of your HLL system for fall clearance charts specific to that system, or for additional factors that must be accounted for before using the charts in these instructions.

5.0 INSPECTION

After equipment has been removed from service, it may not be returned to service until a Competent Person confirms in writing that it is acceptable to do so.

- 5.1 INSPECTION FREQUENCY:** The product shall be inspected before each use by a user and, additionally, by a Competent Person other than the user at intervals of no longer than one year. A higher frequency of equipment use and harsher conditions may require increasing the frequency of Competent Person inspections. The frequency of these inspections should be determined by the Competent Person per the specific conditions of the worksite.
- 5.2 INSPECTION PROCEDURES:** Inspect this product per the procedures listed in the "Inspection and Maintenance Log". Documentation of each inspection should be maintained by the owner of this equipment. An inspection and maintenance log should be placed near the product or be otherwise easily accessible to users. It is recommended that the product is marked with the date of next or last inspection.
- 5.3 DEFECTS:** If the product cannot be returned to service because of an existing defect or unsafe condition, or because the product has been exposed to fall arrest or impact force, then the product must be destroyed.
- 5.4 PRODUCT LIFE:** The functional life of the product is determined by work conditions and maintenance. As long as the product passes inspection criteria, it may remain in service, up to a maximum of 10 years.

6.0 MAINTENANCE, STORAGE, AND REPAIR

Equipment that is in need of maintenance or scheduled for maintenance should be tagged "DO NOT USE". These equipment tags should not be removed until maintenance is performed.

- 6.1 CLEANING:** Periodically clean the lifeline and the exterior of the product with water and a mild soap solution. Rinse the product thoroughly and air dry. Clean labels as necessary. For more information, please refer to the technical bulletin on our website: <https://www.3M.com/FallProtection/Mechanical-Device-Cleaning>
- 6.2 DISPOSAL:** Cut or otherwise disable the lifeline, then dispose of the product appropriately.
- 6.3 REPAIR:** This product is not repairable. Do not attempt to repair this product.
- 6.4 STORAGE AND TRANSPORT:** Store and transport the product in a cool, dry, clean environment out of direct sunlight. Avoid areas where chemical vapors may exist. Thoroughly inspect components after extended storage.

7.0 LABELS and MARKINGS

7.1 SUMMARY: The "Product Labels" figure illustrates labels and markings present on the product. See below for a summary of information provided with each label and marking.

Label images are intended to be representative. Please refer to your product labels for specific information.

Missing or damaged labels must be replaced. All labels must be fully legible.

A	1) Logo Label
B	1) ID Label
C	1) Warning Label

8.0 GLOSSARY OF TERMS

8.1 DEFINITIONS: The following terms and definitions are used in these instructions.

For a comprehensive list of terms and definitions, please visit our website: www.3m.com/FallProtection/ifu-glossary

- **AUTHORIZED PERSON:** A person assigned by the employer to perform duties at a location where the person will be exposed to a fall hazard.
- **COMPETENT PERSON:** One who is capable of identifying existing and predictable hazards in the surroundings or working conditions which are unsanitary, hazardous, or dangerous to employees, and who has authorization to take prompt corrective measures to eliminate them.
- **FALL ARREST SYSTEM:** A collection of Fall Protection equipment configured to protect the user in the event of a fall.
- **QUALIFIED PERSON:** A person with a recognized degree, certificate, or professional standing, or who by extensive knowledge, training, and experience has successfully demonstrated their ability to solve or resolve problems relating to Fall Protection and Rescue systems to the extent required by applicable national, regional, and local regulations.
- **RESCUER:** A person using the Rescue system to perform an assisted rescue.
- **RESTRAINT SYSTEM:** A collection of Fall Protection equipment configured to prevent the user from reaching a fall hazard. No free fall is permitted.
- **USER:** A person who performs activities while protected by a Fall Protection system.

Figure 8 - Product Labels

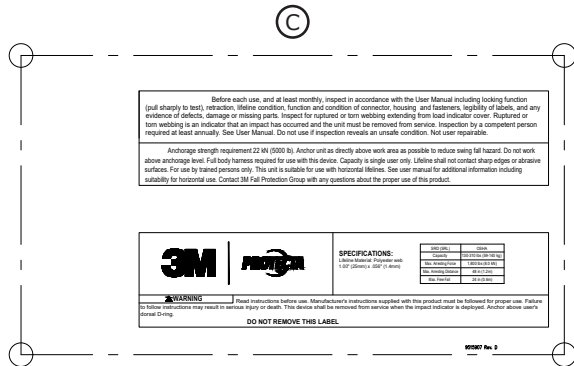
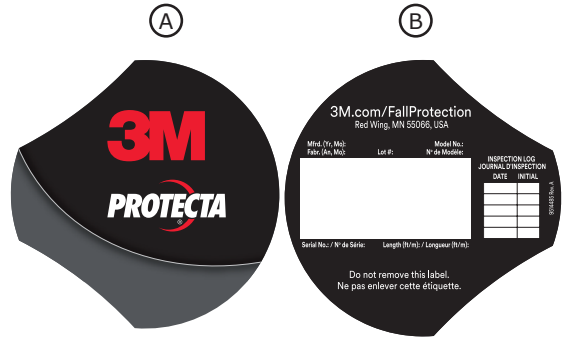
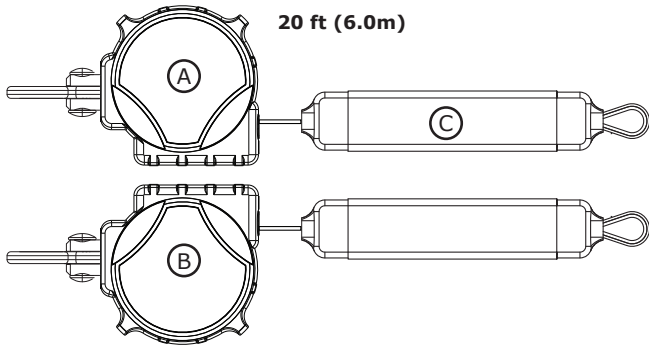
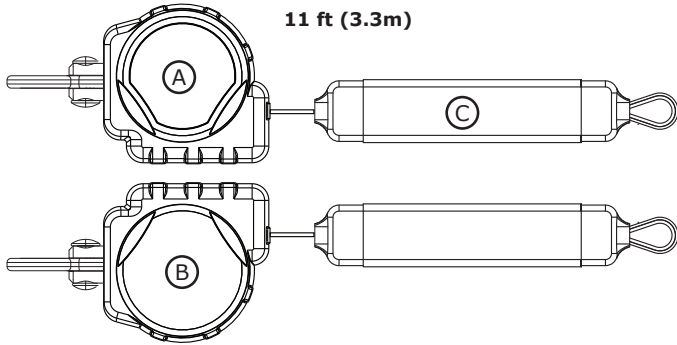

Table 2 – Inspection and Maintenance Log

Model Number (Serial Number):					
Date Purchased:			Date of First Use:		
...					
<input checked="" type="checkbox"/> <i>This product must be inspected by the user before each use. Additionally, a Competent Person other than the user must inspect this equipment at least once each year.</i>					
...					
Component	Inspection Procedure		Inspection Result		
			Pass	Fail	
SRD - General (Figure 9.1)	Inspect for loose bolts and bent or damaged parts.		<input type="checkbox"/>	<input type="checkbox"/>	
	Inspect Housing (A) for distortion, cracks, or other damage.		<input type="checkbox"/>	<input type="checkbox"/>	
	Inspect the Swivel Eye (B) for distortion, cracks, or other damage. The Swivel Eye should be attached securely to the SRD, but should pivot freely.		<input type="checkbox"/>	<input type="checkbox"/>	
	The Lifeline (C) should pull out and retract fully without hesitation or creating a slack line condition.		<input type="checkbox"/>	<input type="checkbox"/>	
	Ensure device locks up when lifeline is jerked sharply. Lockup should be positive with no slipping.		<input type="checkbox"/>	<input type="checkbox"/>	
	Look for signs of corrosion on the entire unit.		<input type="checkbox"/>	<input type="checkbox"/>	
Connectors (Figure 9.2)	Inspect all SRD connectors for signs of damage and corrosion. Verify that all connectors are working properly. Where present: Gates (A) should open, close, lock, and unlock properly; Swivel Eyes (B) should rotate without interference; and locking buttons and pins should function correctly.		<input type="checkbox"/>	<input type="checkbox"/>	
Web Lifeline (Figure 9.3)	Inspect the webbing for Cuts (A), Frays (B), broken fibers, tears, abrasion, Heavy Soiling (C), mold, Burns (D), and discoloration. Inspect the lifeline stitching for pulled or cut stitches, since broken stitches may indicate that the product has been impact-loaded and must be removed from service.		<input type="checkbox"/>	<input type="checkbox"/>	
Energy Absorber (Figure 10)	Verify that the integral energy absorber has not been activated. Verify that the Lifeline Cover (A) has not pulled out from the Energy Absorber Cover (B) on either end. None of the Energy Absorber Webbing (C) should be exposed. The Energy Absorber Cover should also be secure and free of Tears (D) or other damage.		<input type="checkbox"/>	<input type="checkbox"/>	
Labels (Figure 8)	All labels are present and fully legible.		<input type="checkbox"/>	<input type="checkbox"/>	
Fall Protection Equipment	Additional Fall Protection equipment that is used with the product is installed and inspected per the manufacturer instructions.		<input type="checkbox"/>	<input type="checkbox"/>	
...					
<input checked="" type="checkbox"/> <i>If the product fails an inspection procedure, then the product fails overall inspection. If the product fails inspection, remove it from service immediately. Clearly tag the product "DO NOT USE". See Section 5 for more information.</i>					
...					
Inspection Type:	<input type="checkbox"/> User	<input type="checkbox"/> Competent Person	Overall Inspection Result:	<input type="checkbox"/> Pass	<input type="checkbox"/> Fail
Inspected By:			Date of Inspection:		
Signature:			Next Inspection Due:		
...					
Additional Notes:					

Figure 9 - General Inspection

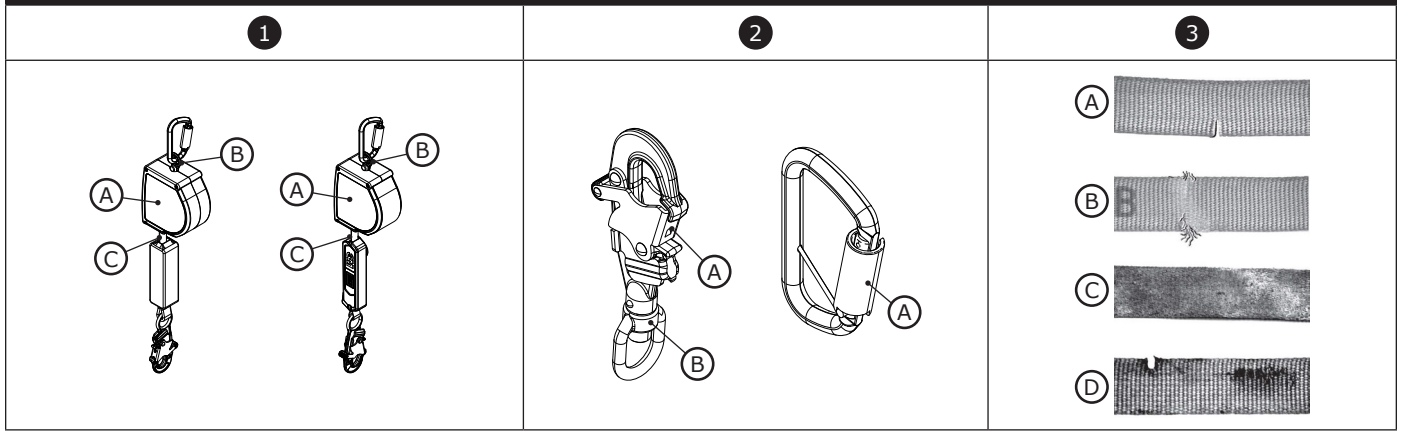
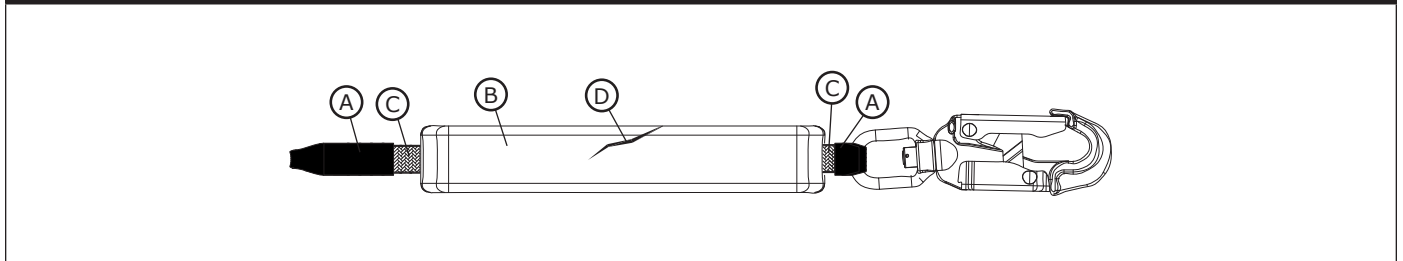

Figure 10 - Energy Absorber Inspection



GLOBAL PRODUCT WARRANTY, LIMITED REMEDY AND LIMITATION OF LIABILITY

WARRANTY: THE FOLLOWING IS MADE IN LIEU OF ALL WARRANTIES OR CONDITIONS, EXPRESS OR IMPLIED, INCLUDING THE IMPLIED WARRANTIES OR CONDITIONS OF MERCHANTABILITY OR FITNESS FOR A PARTICULAR PURPOSE.

Unless otherwise provided by local laws, 3M fall protection products are warranted against factory defects in workmanship and materials for a period of one year from the date of installation or first use by the original owner.

LIMITED REMEDY: Upon written notice to 3M, 3M will repair or replace any product determined by 3M to have a factory defect in workmanship or materials. 3M reserves the right to require product be returned to its facility for evaluation of warranty claims. This warranty does not cover product damage due to wear, abuse, misuse, damage in transit, failure to maintain the product or other damage beyond 3M's control. 3M will be the sole judge of product condition and warranty options.

This warranty applies only to the original purchaser and is the only warranty applicable to 3M's fall protection products. Please contact 3M's customer service department in your region for assistance.

LIMITATION OF LIABILITY: TO THE EXTENT PERMITTED BY LOCAL LAWS, 3M IS NOT LIABLE FOR ANY INDIRECT, INCIDENTAL, SPECIAL OR CONSEQUENTIAL DAMAGES INCLUDING, BUT NOT LIMITED TO LOSS OF PROFITS, IN ANY WAY RELATED TO THE PRODUCTS REGARDLESS OF THE LEGAL THEORY ASSERTED.



Fall Protection

USA

3833 SALA Way
Red Wing, MN 55066-5005
Toll Free: 800.328.6146
Phone: 651.388.8282
Fax: 651.388.5065
3Mfallprotection@mmm.com

Canada

600 Edwards Blvd, Unit #2
Mississauga, ON L5T 2V7
Phone: 905.795.9333
Toll-Free: 800.387.7484
Fax: 888.387.7484
3Mfallprotection-ca@mmm.com

Brazil

Rodovia Anhanguera, km 110
Sumaré - SP
CEP: 13181-900
Brasil
Phone: 0800-013-2333
falecoma3m@mmm.com

Mexico

Av. Santa Fe No. 190
Col. Santa Fe, Ciudad de Mexico
CP 01219, Mexico
Phone: 01 800 120 3636
3msaludocupacional@mmm.com

EMEA (Europe, Middle East, Africa)

EMEA Headquarters:
Le Broc Center
Z.I. 1re Avenue - BP15
06511 Carros Le Broc Cedex
France
Phone: + 33 04 97 10 00 10
Fax: + 33 04 93 08 79 70
informationfallprotection@mmm.com

United Kingdom

3M Centre
Cain Road
Bracknell, RG12 8HT
Phone: 0870 60800 60
www.3M.co.uk/construction

Slovakia

Capital Safety Group - Banská
Bystrica, s.r.o.
Jegorovova 35
974 01 Banská Bystrica
Slovak Republic
Phone: + 421 (0)47 00 330
Fax: + 421 (0)47 00 336
informationfallprotection@mmm.com

Australia & New Zealand

137 McCredie Road
Guildford
Sydney, NSW, 2161
Australia
Toll-Free : 1800 245 002 (AUS)
Toll-Free : 0800 212 505 (NZ)
3msafetyauucs@mmm.com

Asia

Singapore:
1 Yishun Avenue 7
Singapore 768923
Phone: +65-6450 8888
Fax: +65-6552 2113
TotalFallProtection@mmm.com

China:

38/F, Maxdo Center, 8 Xing Yi Rd
Shanghai 200336, P R China
Phone: +86 21 62753535
Fax: +86 21 52906521
3MFallProtection-CN@mmm.com

Korea:

3M Korea Ltd
18F, 82 Uisadang-daero,
Yeongdeungpo-gu, Seoul
Phone: +82-80-033-4114
Fax: +82-2-3771-4977
3msupport.kr@mmm.com

Japan:

3M Japan Ltd
6-7-29, Kitashinagawa, Shinagawa-ku,
Tokyo
Phone: +81-570-011-321
Fax: +81-3-6409-5818
psd.jp@mmm.com

WEBSITE:
3M.com/FallProtection



DECLARATION OF CONFORMITY:
3M.com/FallProtection/DOC

(European Union and United Kingdom)